

ITEM NO.	PART NUMBER	Description	QTY.
1	A000087	SWIVEL ASSY, J3DSF	1
2	A000029	JGB-DSA3N	1
3	A000088	SHIFTER ASSY, J3DSF	1
4	A000089	HANDLE ASSY, J3 FLIP CONFIGURATION	1

REVISIONS			
LTR	DESCRIPTION OR ECN No.	APP.	DATE
A	NEW SHIFTER AND SHIFTER RING	-	11-1-09
B	-	-	-
C	-	-	-

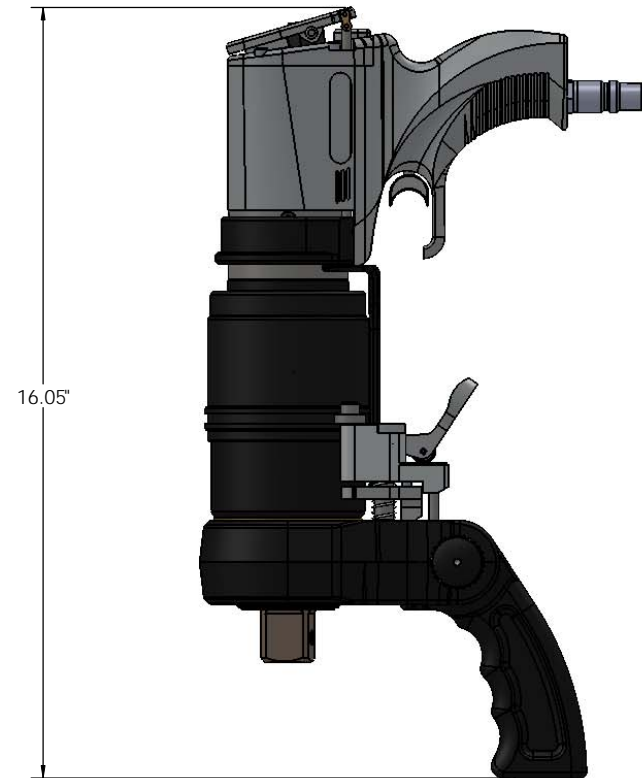
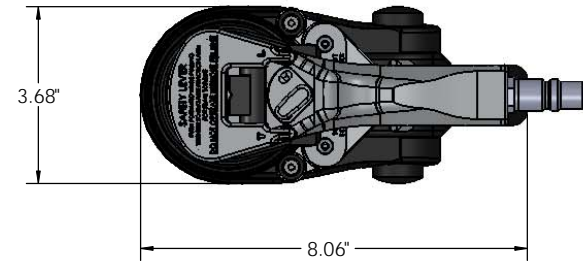
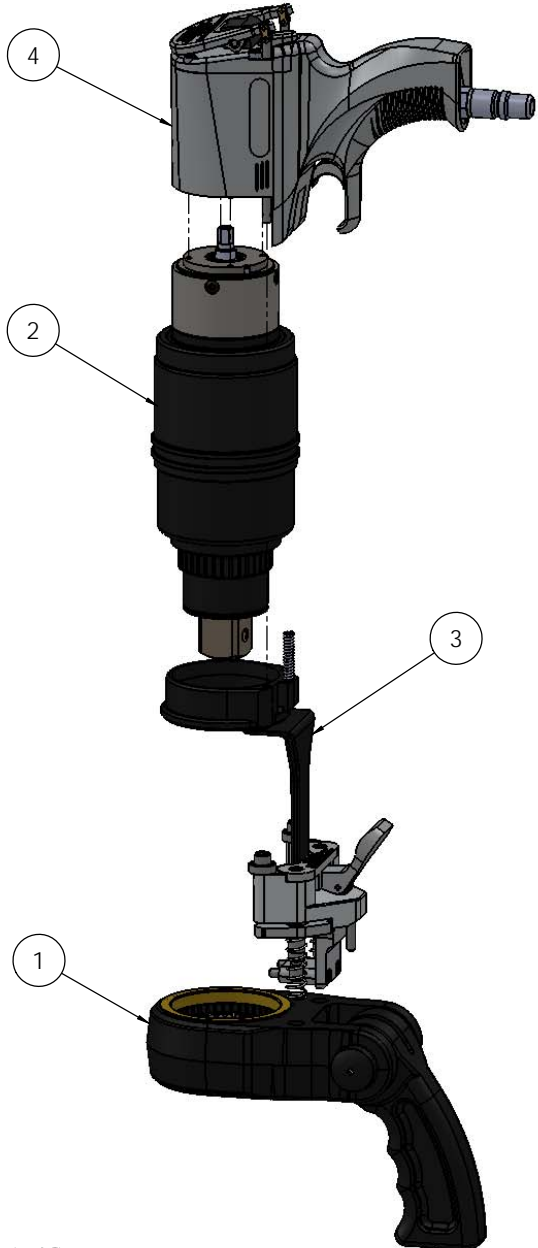

This drawing is the property of The Torc Gun Company and the information thereon is to be treated as confidential. It is not to be used, copied or disclosed to outside parties without our written consent.

WEIGHT	OVERALL LENGTH	SQUARE DRIVE SIZE	MAX SPEED HIGH	MAX SPEED LOW	MAX TORQUE HIGH	MAX TORQUE LOW
	16.05"	1"			3250	

© COPYRIGHT 2010, THE TORC GUN COMPANY

TOLERANCE	MATERIAL	TITLE: JGUN-DSA3N
xxx=±.005	-	ILLUSTRATED PARTS BREAK-DOWN
.xx=±.010	-	
x/x=±1/64	-	
* = ±1"	-	
UNLESS OTHERWISE SPECIFIED	FINISH	DRAWN: MCH
SCALE	-	DATE: 2-25-10
NTS	-	CHECKED: -
		DATE: -
		SIZE: C
		DRAWING NUMBER: JGUN-DSA3N

