

ITEM NO.	PART NUMBER	DESCRIPTION	QTY.
1	A000083	HANDLE ASSY, J.5-J1 FLIP CONFIGURATION	1
2	A000031	JGB-DSA1N	1
3	A000046	SWIVEL ASSY, JP5DSF/J1DSF	1
4	A000041	SHIFTER ASSY, J1DSF	1

REVISIONS			
LTR	DESCRIPTION OR ECN No.	APP.	DATE
A	CHANGED SHIFTER COLLAR AND LINKS	MCH	4-7-09
B	-	-	-
C	-	-	-

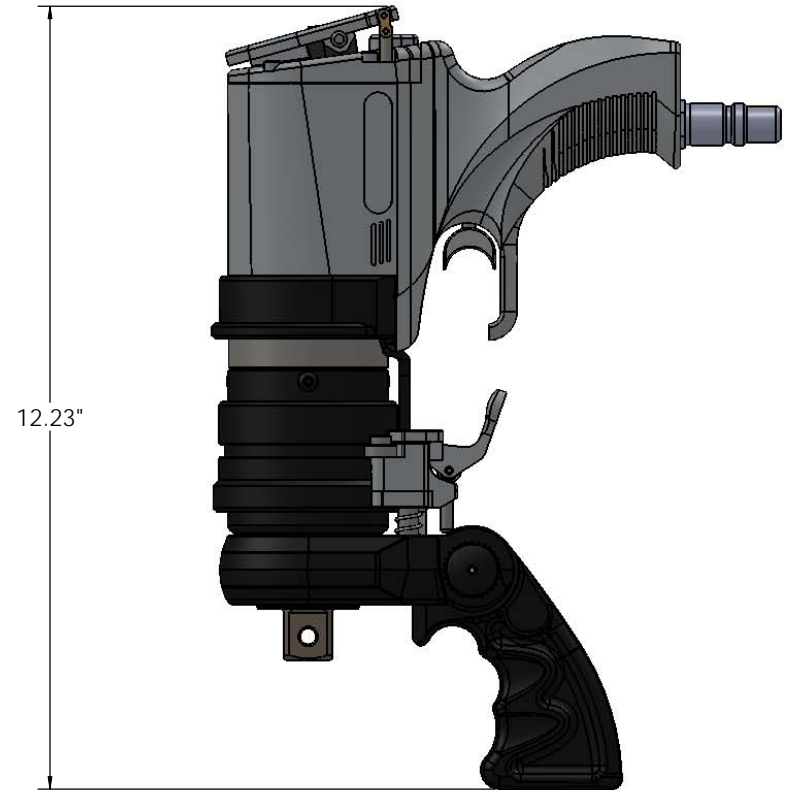
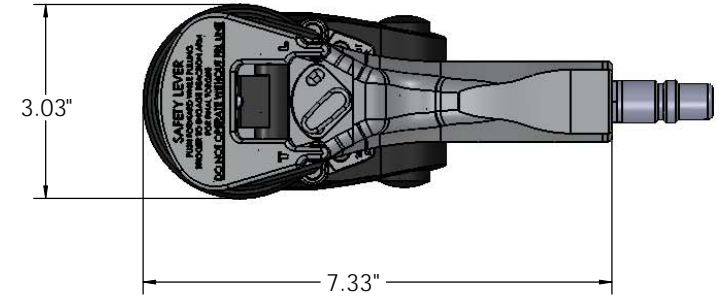
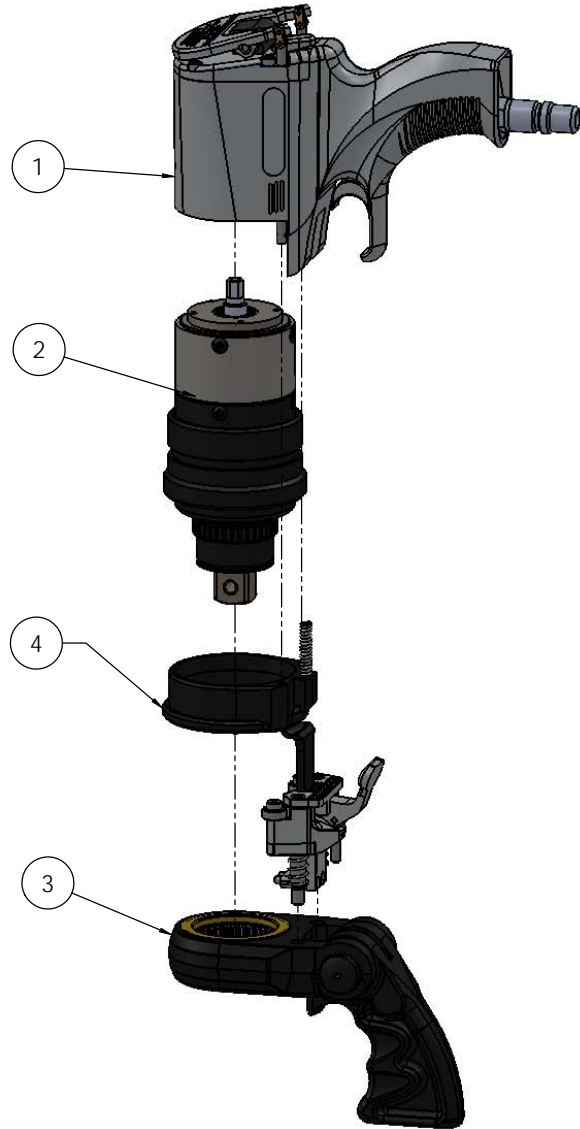

© COPYRIGHT 2009, THE TORC GUN COMPANY

TOLERANCE	MATERIAL	TITLE: JGUN-DSA1N
xxx = ±.005	-	ILLUSTRATED PARTS BREAK-DOWN
.xx = ±.010	-	
x/xx = ±1/64	-	
* = ±1°	-	
UNLESS OTHERWISE SPECIFIED	FINISH	DRAWN: MCH
SCALE	-	DATE: 2/18/10
NTS	-	CHECKED: MCH
		DATE: -
		SIZE: 1/2" DRAWING NUMBER: JGUN-DSA1N

This drawing is the property of The Torc Gun Company and the information thereon is to be treated as confidential. It is not to be used, copied or disclosed to outside parties without our written consent.

WEIGHT	OVERALL LENGTH	SQUARE DRIVE SIZE	MAX SPEED HIGH	MAX SPEED LOW	MAX TORQUE HIGH	MAX TORQUE LOW
	12.23"	3/4"			1250	