

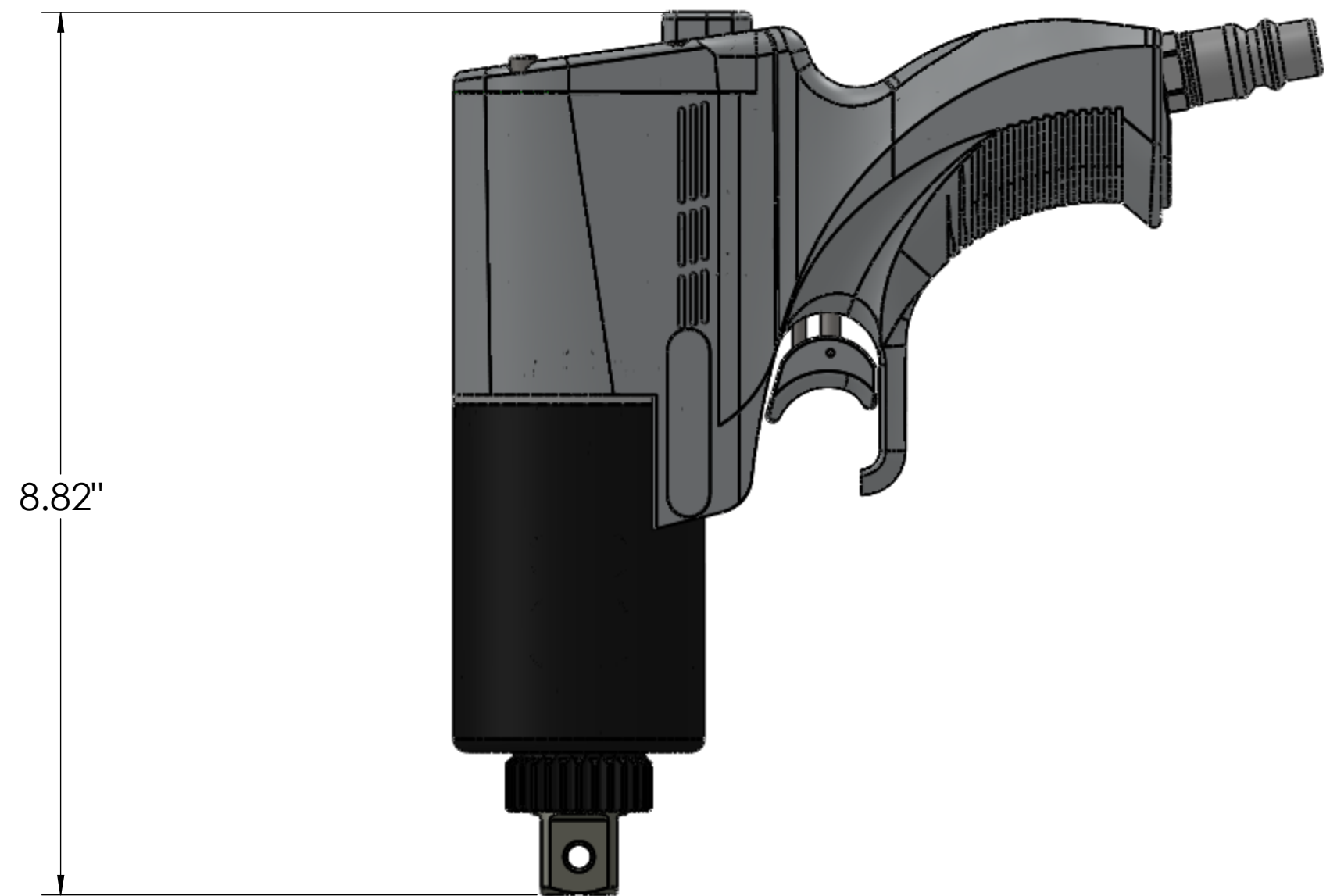

ITEM NO.	PART NUMBER	DESCRIPTION	QTY.
1	A000141	JGB-A1	1
2	A000078	HANDLE ASSY, JP15-J3SS	1

REVISIONS			
LTR	DESCRIPTION OR ECN No.	APP.	DATE
A	-	-	-
B	-	-	-
C	-	-	-

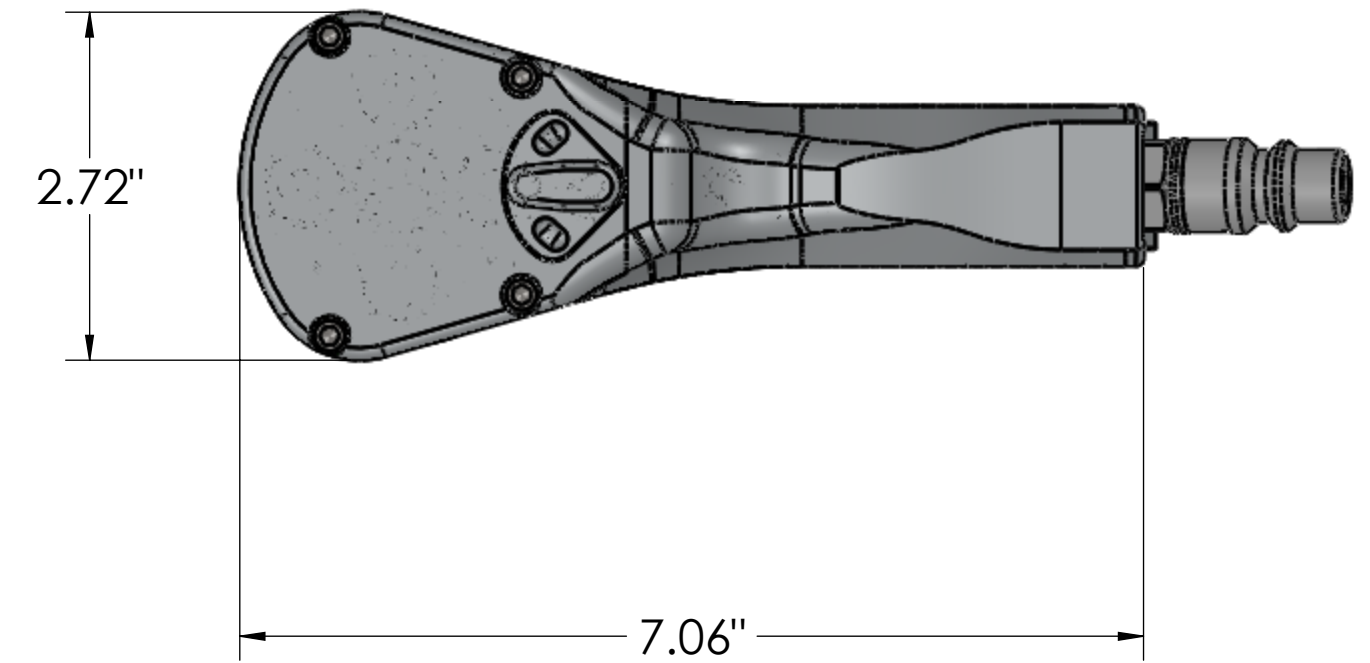
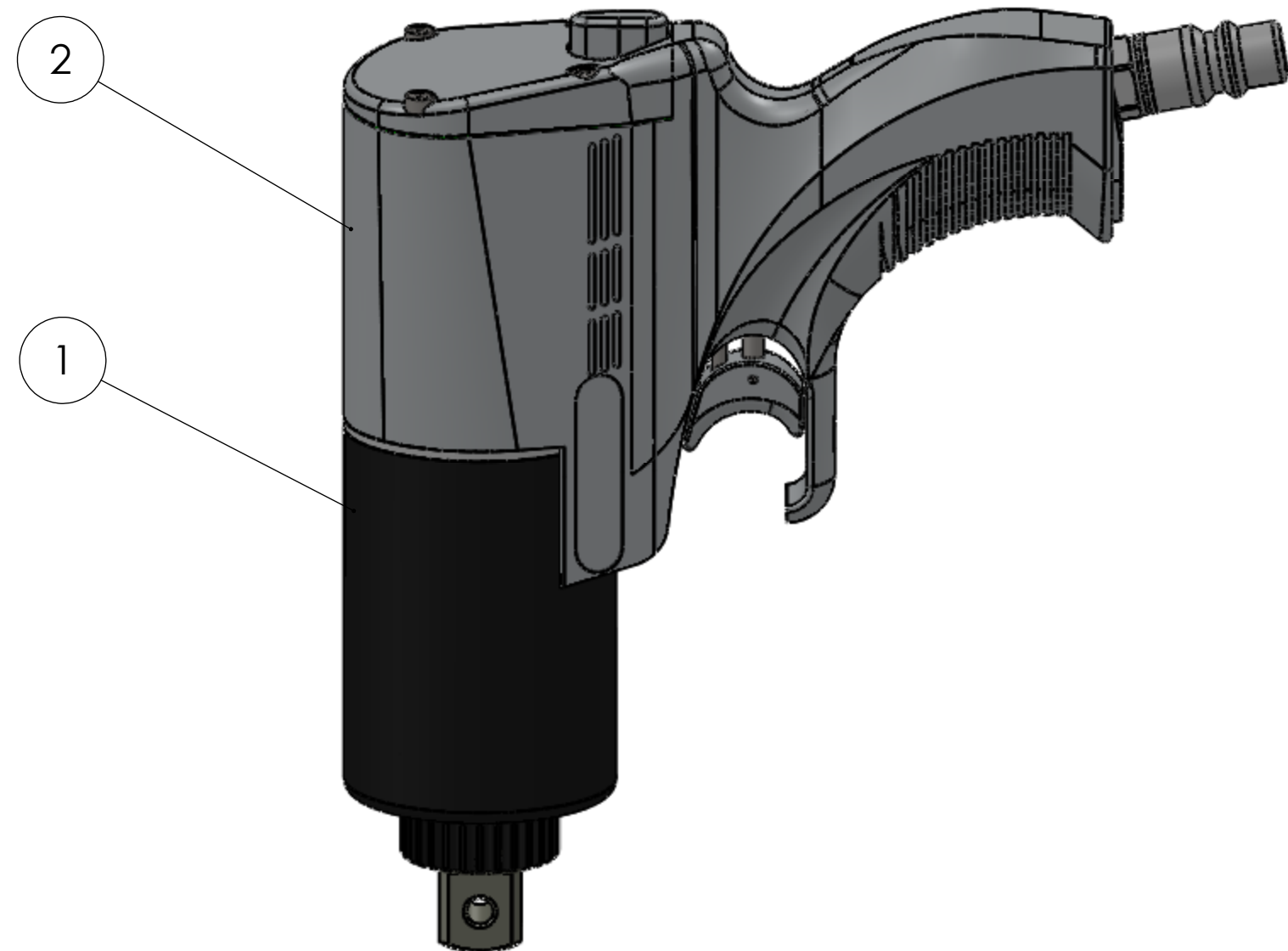

© COPYRIGHT 2010, THE TORC GUN COMPANY

TOLERANCE .XXX=±.005 .XX=±.010 X/X=±1/64 ∠ =±1° UNLESS OTHERWISE SPECIFIED	MATERIAL	TITLE: JGUN-A1	
	FINISH	ILLUSTRATED PARTS BREAKDOWN	
	SCALE	 DRAWN: MCH      CHECKED: - DATE: 3-1-10      DATE: - SIZE: C      DRAWING NUMBER: JGUN-A1	
	NTS		

This drawing is the property of The Torc Gun Company and the information thereon is to be treated as confidential. It is not to be used, copied or disclosed to outside parties without our written consent.

WEIGHT	OVERALL LENGTH	SQUARE DRIVE SIZE	MAX SPEED HIGH	MAX SPEED LOW	MAX TORQUE HIGH	MAX TORQUE LOW
	8.82"	3/4"			1250	

ITEM NO.	PART NUMBER	DESCRIPTION	QTY.
1	A000141	JGB-A1	1
2	A000079-SAFETY HANDLE	J1AP-J3AP SAFETY HANDLE ASSY	1

REVISIONS			
LTR	DESCRIPTION OR ECN No.	APP.	DATE
A	-	-	-
B	-	-	-
C	-	-	-

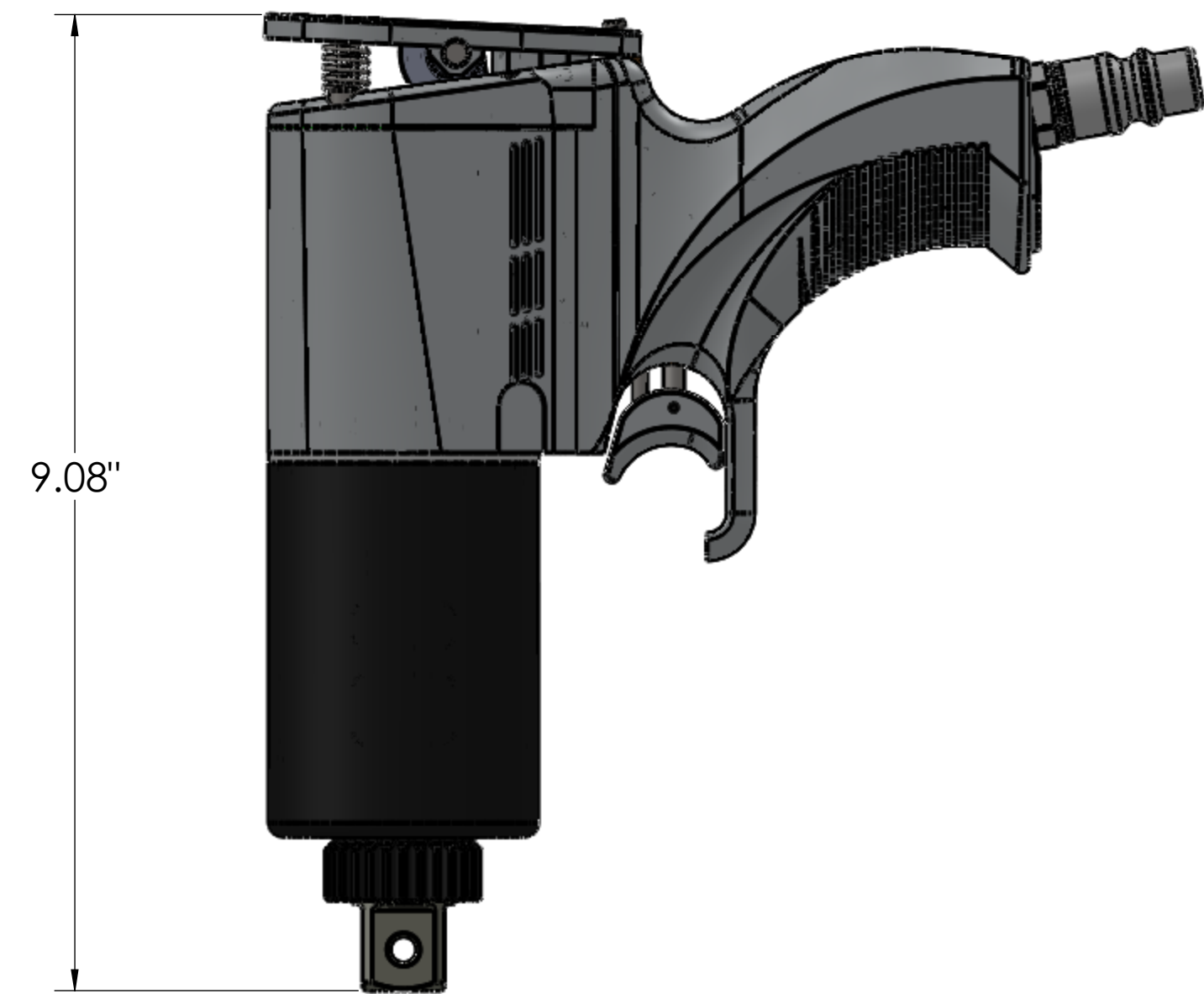
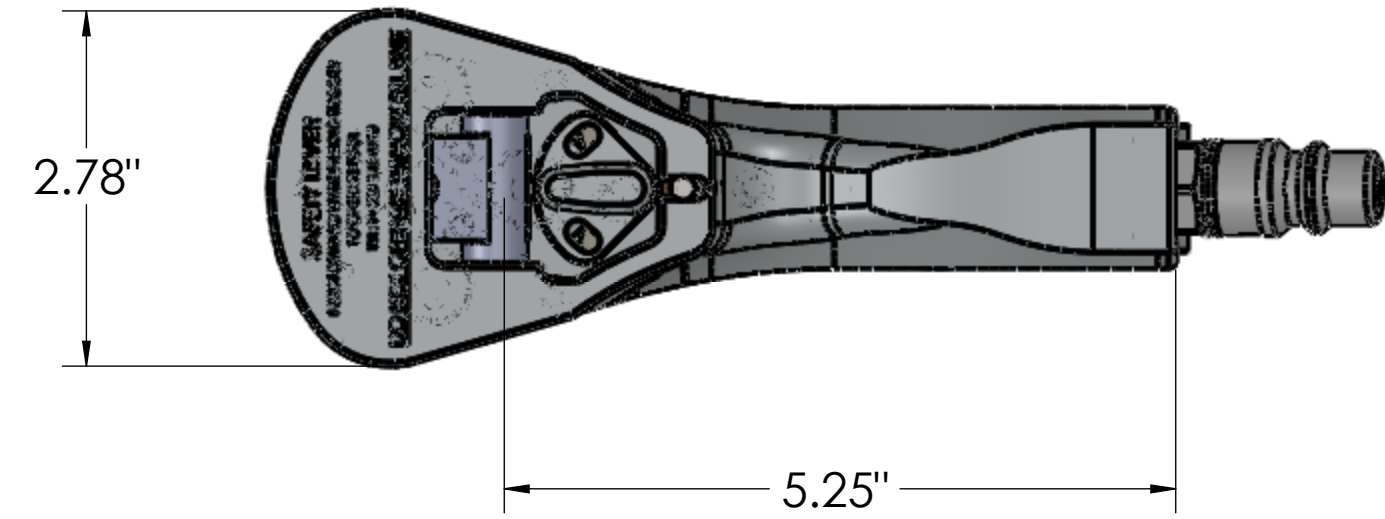
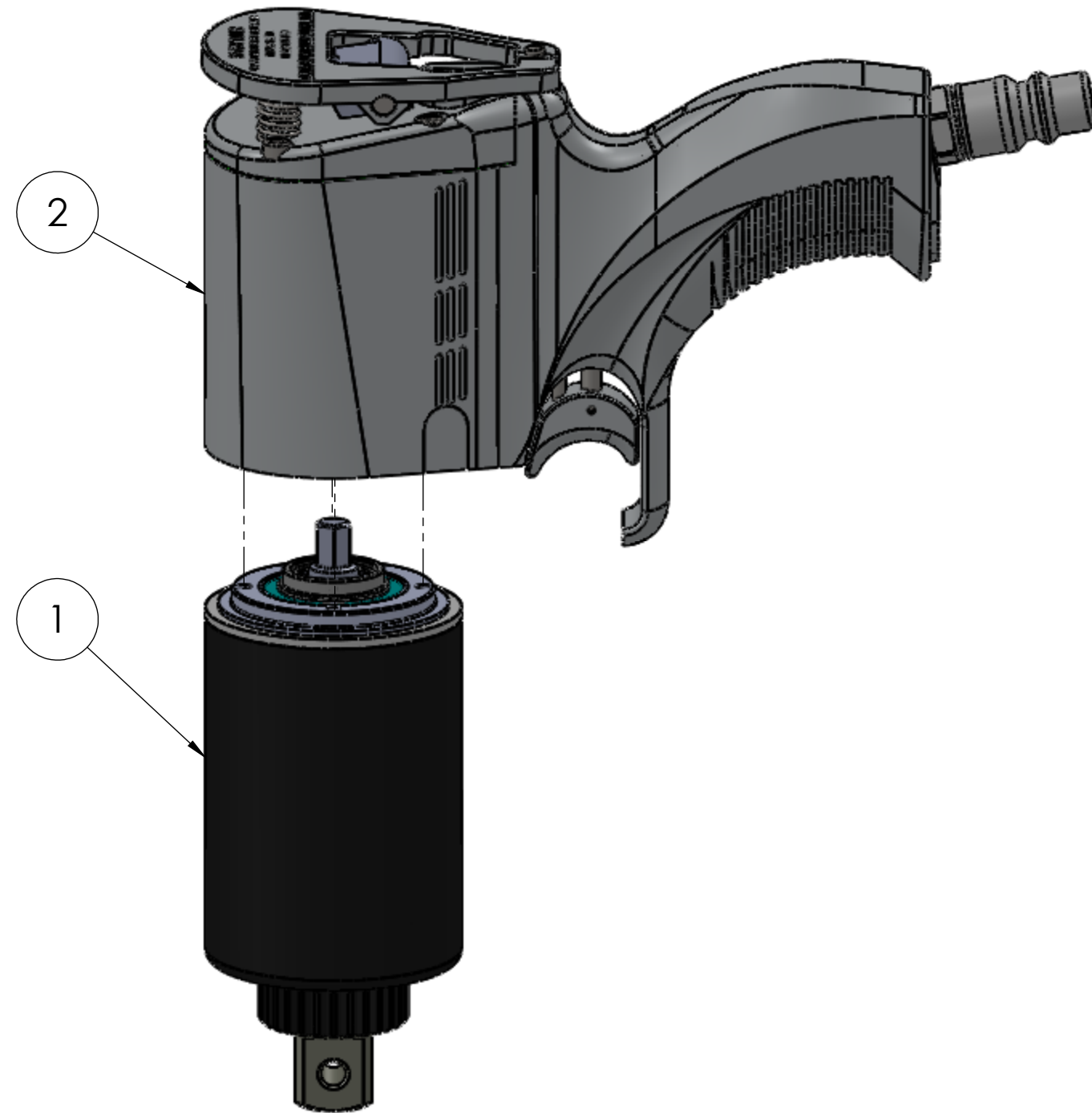

© COPYRIGHT 2010, THE TORC GUN COMPANY

TOLERANCE	MATERIAL	TITLE: JGUN-A1-SAFETY HANDLE ILLUSTRATED PARTS BREAKDOWN	
.XXX=±.005	-		
.XX=±.010	-		
X/X=±1/64	-		
∠ =±1°	-		
UNLESS OTHERWISE SPECIFIED	FINISH		
SCALE	-	DRAWN: MCH	CHECKED: -
NTS	-	DATE: 3-1-10	DATE: -
		DRAWING NUMBER: JGUN-A1	

This drawing is the property of The Torc Gun Company and the information thereon is to be treated as confidential. It is not to be used, copied or disclosed to outside parties without our written consent.

WEIGHT	OVERALL LENGTH	SQUARE DRIVE SIZE	MAX SPEED HIGH	MAX SPEED LOW	MAX TORQUE HIGH	MAX TORQUE LOW
	9.08"	3/4"			1250	