

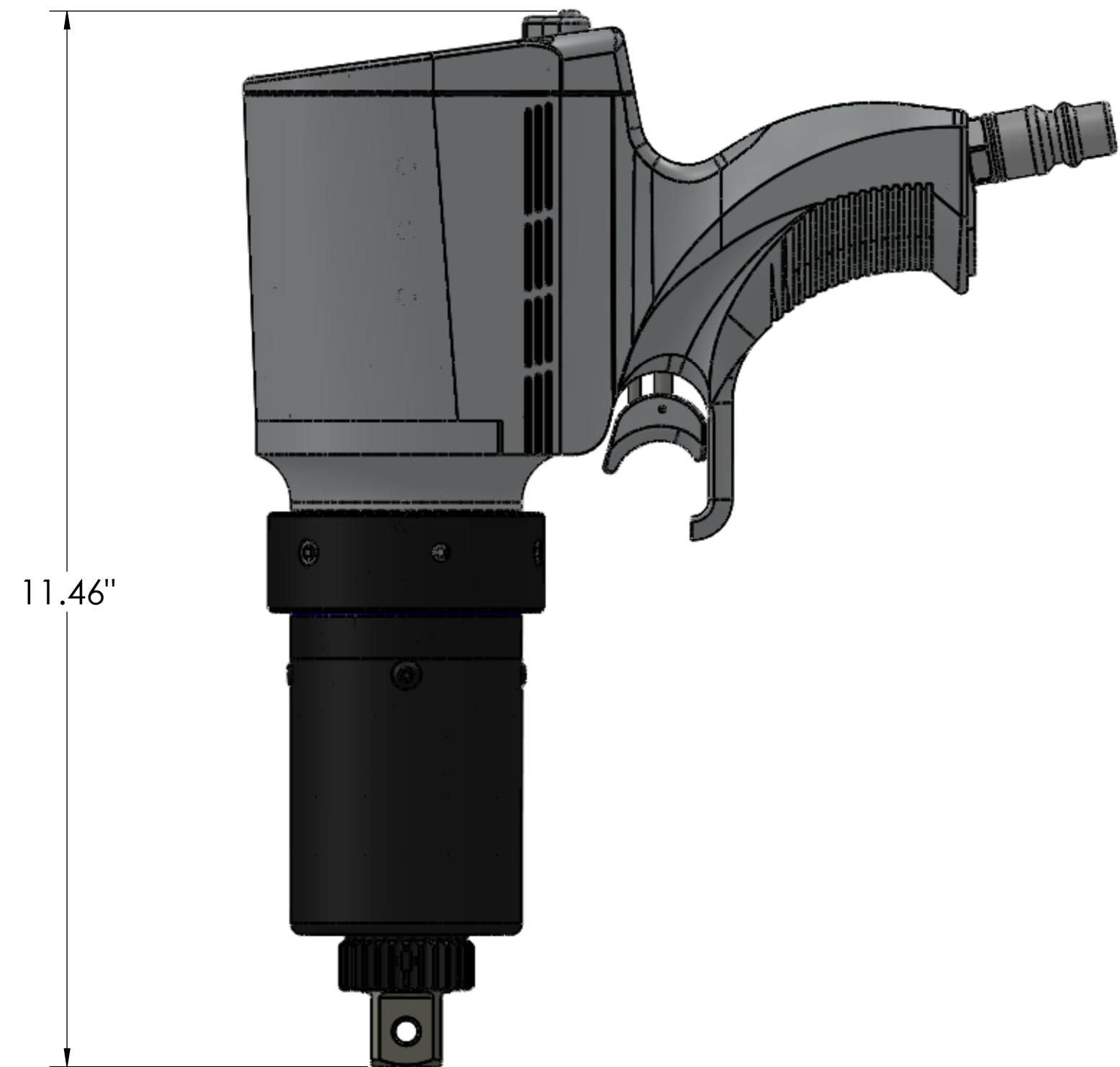

ITEM NO.	PART NUMBER	DESCRIPTION	QTY.
1	A000082	JGB-A1-AP-WG	1
2	A000081	HANDLE ASSY, J1-AP-WG	1

REVISIONS			
LTR	DESCRIPTION OR ECN No.	APP.	DATE
A	REVISED HANDLE ASSY	MCH	11-10-10
B	-	-	-
C	-	-	-

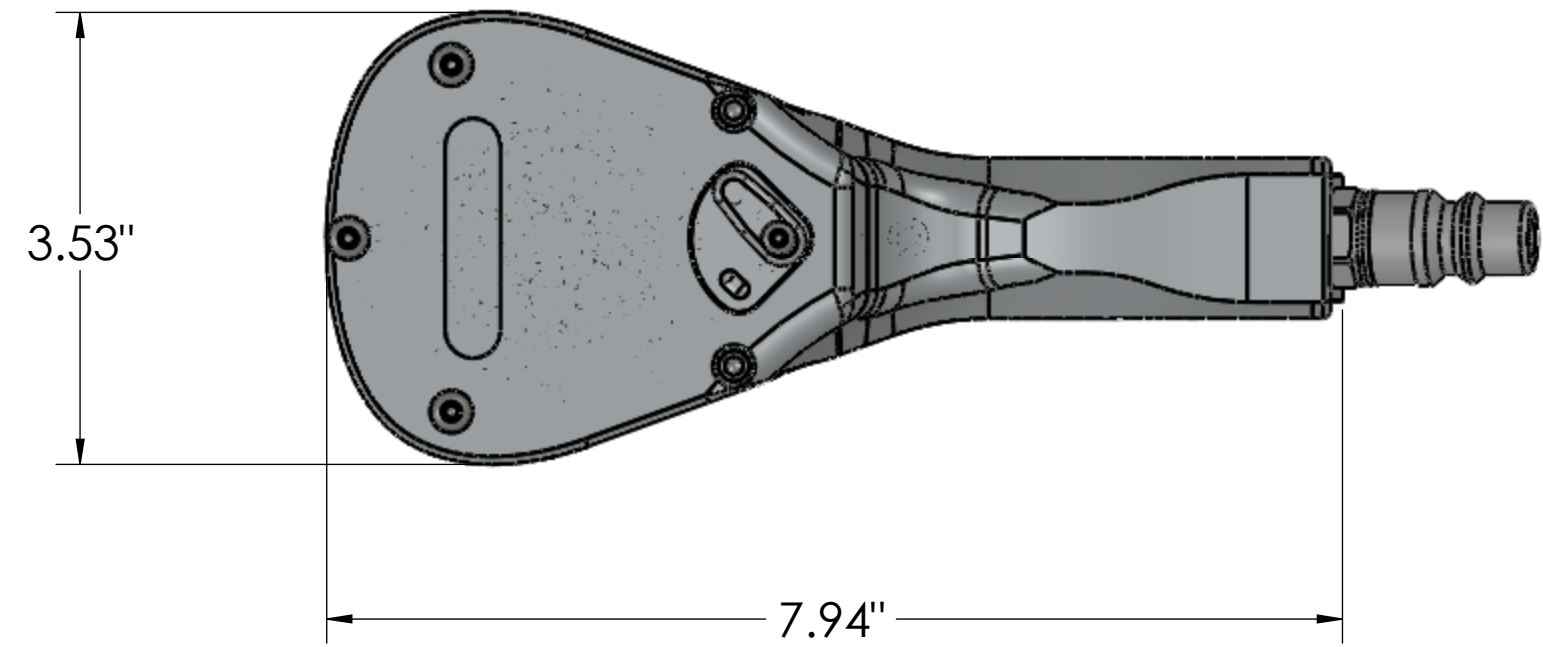
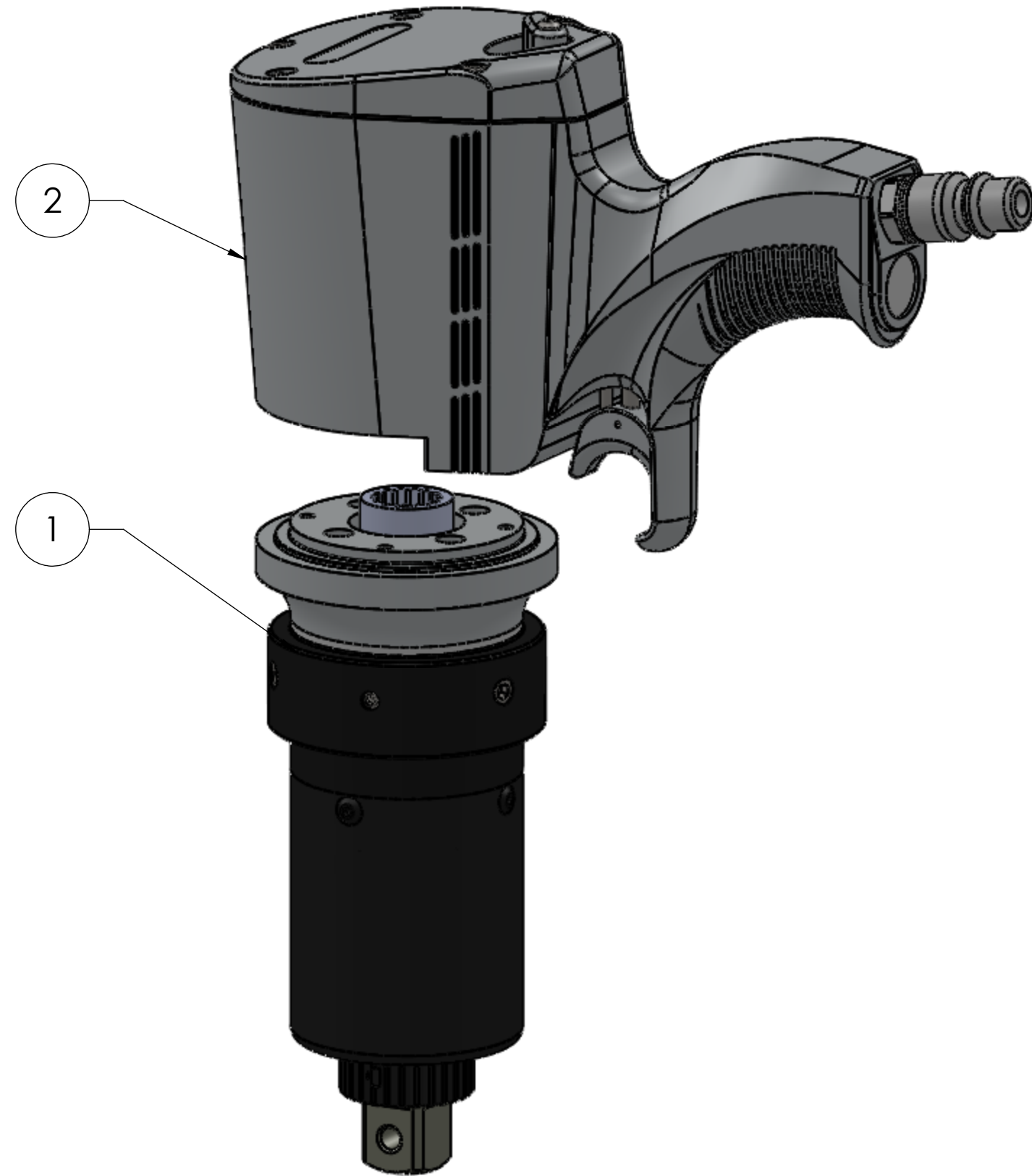

© COPYRIGHT 2009, THE TORC GUN COMPANY

TOLERANCE	MATERIAL	TITLE: JGUN-A1-AP-WG	
.XXX=±.005	-	ILLUSTRATED PARTS BREAKDOWN	
.XX=±.010	-		
X/X=±1/64	-		
∠=±1°	-	DRAWN: MCH	CHECKED: MCH
UNLESS OTHERWISE SPECIFIED	FINISH	DATE: -	DATE: -
SCALE	-	SIZE DRAWING NUMBER:	
NTS	-	C JGUN-A1-AP-WG	

This drawing is the property of The Torc Gun Company and the information thereon is to be treated as confidential. It is not to be used, copied or disclosed to outside parties without our written consent.

WEIGHT	OVERALL LENGTH	SQUARE DRIVE SIZE	MAX SPEED HIGH	MAX SPEED LOW	MAX TORQUE HIGH	MAX TORQUE LOW
	11.46"	3/4"			1050	